

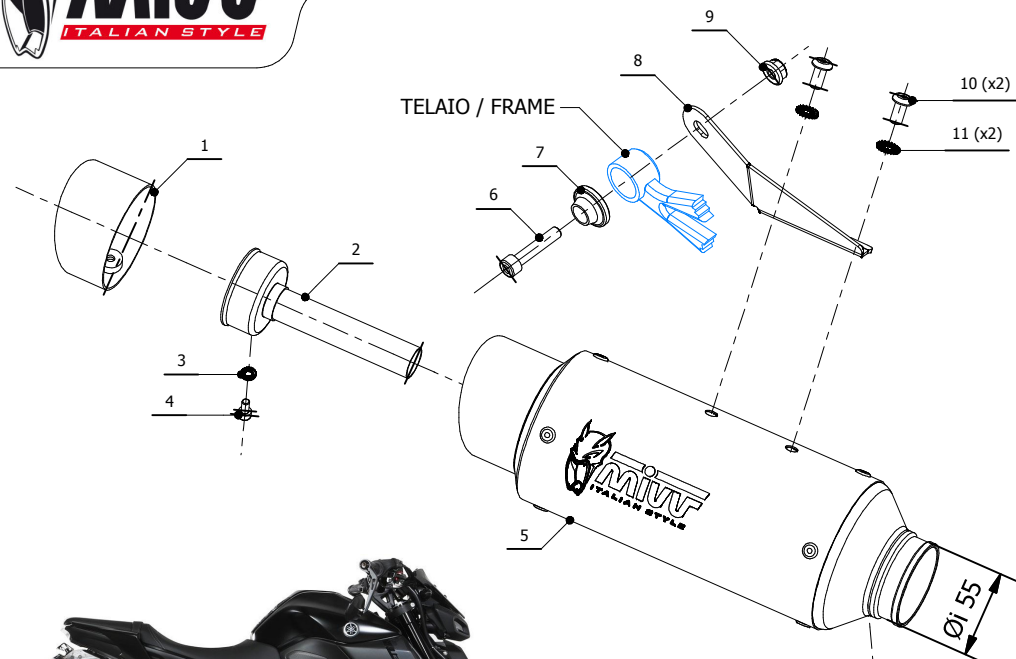

YAMAHA MT-125 2020- / YAMAHA YZF R125 2019-

GP PRO



ELENCO PARTI / PARTS LIST			
#	QTÀ / QTY	DESCRIZIONE / DESCRIPTION	CODICE / CODE
1	1	Griglia / Grid	50.DK.127.0
2	1	DB killer / DB killer	50.DK.145.0
3	1	Rondella di sicurezza M5 / Safety washer M5	50.73.770.0
4	1	Vite M5 x 10 / Screw M5 x 10	50.73.858.1
5	1	Silenziatore / Muffler	GP PRO 220
6	1	Vite M8x40 / Screw M8x40	50.73.075.1
7	1	Rondella in alluminio nera / Black aluminium washer	50.73.221.1
8	1	Staffa / Bracket	50.SS.1288.0
9	1	Dado M8 flangiato / Flanged nut M8	50.73.393.1
10	2	Vite M8 x 16 / Screw M8 x 16	50.73.098.1
11	2	Rondella di sicurezza / Safety washer	50.73.604.1
12	3	Molla media / Mid-size spring	50.73.359.1
13	3	Gommino per molla / Rubber for spring	50.73.210.1
14	1	Tubo collettore / Down pipe	9773Y067S2A
15	1	Tubo di raccordo / Link pipe	9773Y067S2B

50.73.111.1



TAPPO SONDA LAMBDA
Usare su versioni Euro4 (RE39)

LAMBDA PROBE CAP
Use only on Euro4 version (RE39)



Catalytic Converter
Cod. ACC.076.A1

Optional for Y.067.LXBP
Included in Y.067.KXBP

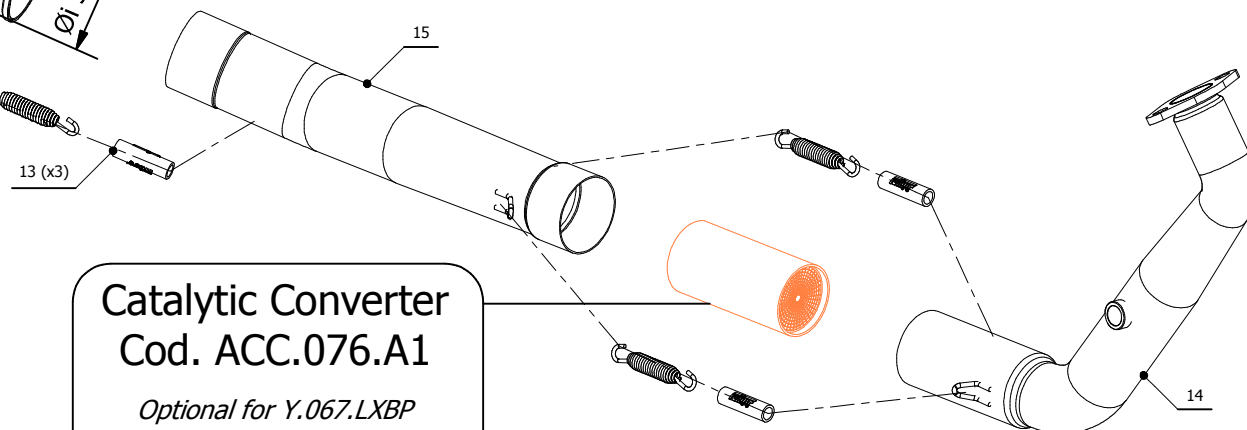

APPLICAZIONI / APPLICATIONS

CODICE / CODE	SILENZIATORE / MUFFLER	TUBO / PIPE	NOTE
Y.067.LXBP			CATALYTIC CONVERTER NOT INCLUDED
Y.067.KXBP	STEEL BLACK	INOX / ST. STEEL	CATALYTIC CONVERTER INCLUDED

ATTENZIONE: La rimozione del riduttore di rumore è considerata una manomissione dell'impianto di scarico che comporta la perdita dell'omologazione per utilizzo stradale e della garanzia prodotto. In caso di rimozione del riduttore di rumore l'impianto di scarico è in configurazione "racing" e può essere utilizzato solo in pista. La griglia frangifiamma può essere rimontata anche in assenza del riduttore di rumore, tuttavia l'impianto resta in configurazione "racing" e utilizzabile esclusivamente in pista.

WARNING: Removal of the noise reducer is considered a tampering of the exhaust system which entails the loss of both the type approval for road use and the product warranty. In case of removal of the noise reducer the exhaust system is in "racing" configuration and can be only used on track. The flame arrestor can be reassembled even without the noise reducer, However, the system remains in "racing" configuration and can be only used on track.