



EVOTECH®
P E R F O R M A N C E

Installation Instructions

YAMAHA XSR900 TAIL TIDY

Product Reference - 13226

Kit Contents

- | | |
|------------------------------------|---|
| A 1 x Main Tail Tidy | I 2 x Plastic Screws and Nuts |
| B 1 x Cover Bracket | J 4 x M6 - 25 Button Screws |
| C 1 x Light Mount | K 4 x M6 Nyloc Nuts |
| D 1 x Reflector Bracket | L 4 x M6 Washers |
| E 1 x LED Light Unit & Nuts | M 4 x M4 - 10 Countersink Screws |
| F 1 x Wiring Connector | N 4 x M4 Washers |
| G 1 x Reflector | O 5 x Cable Ties |
| H 1 x Rubber Cap | P 8 x M4 - 10 Button Screws |

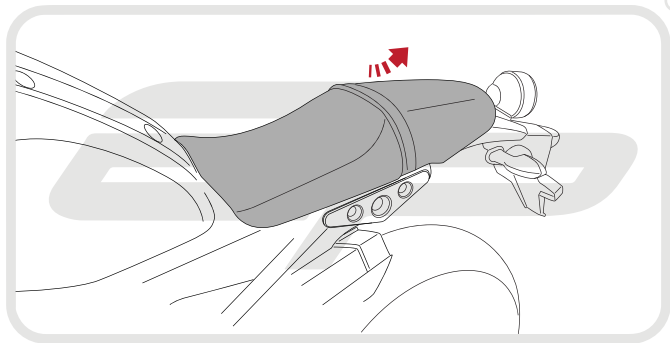

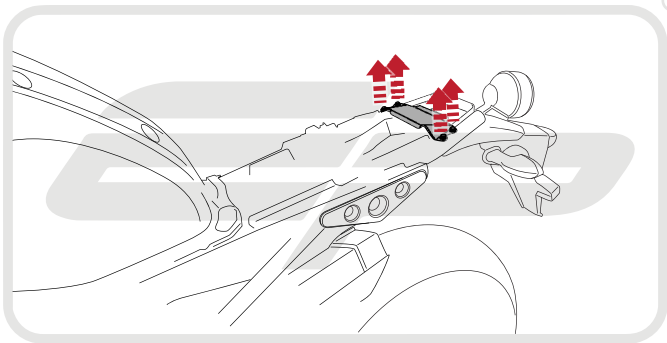

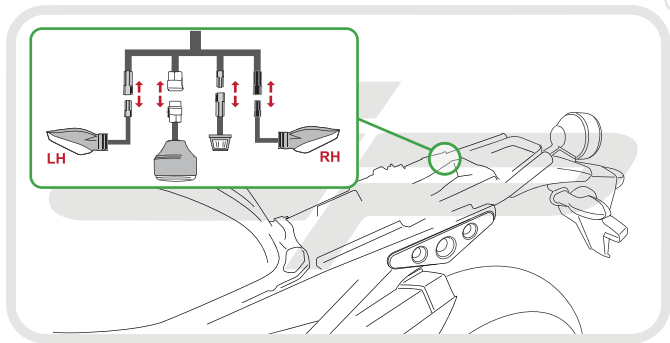

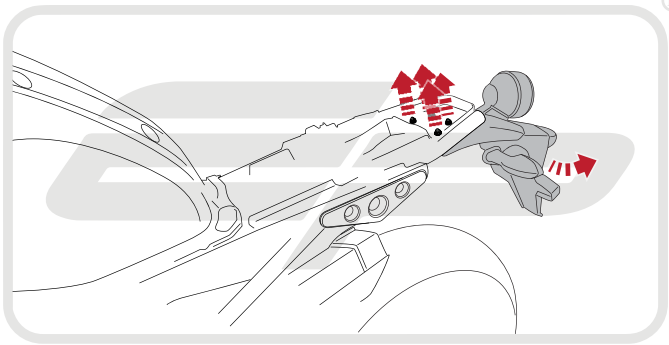

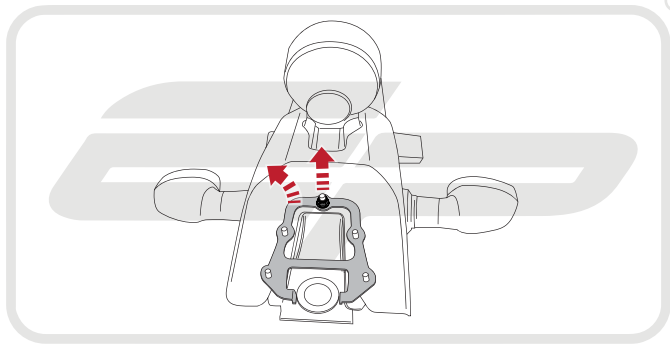

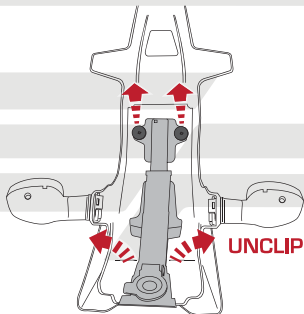

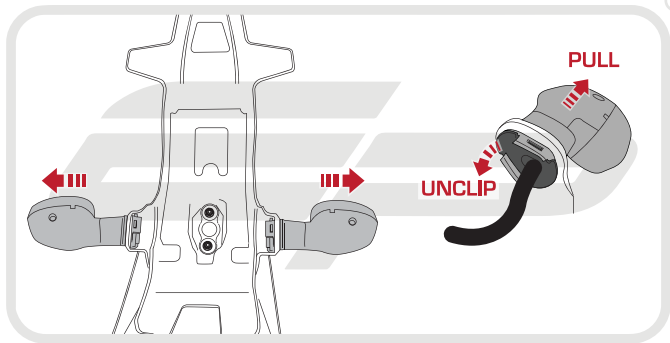

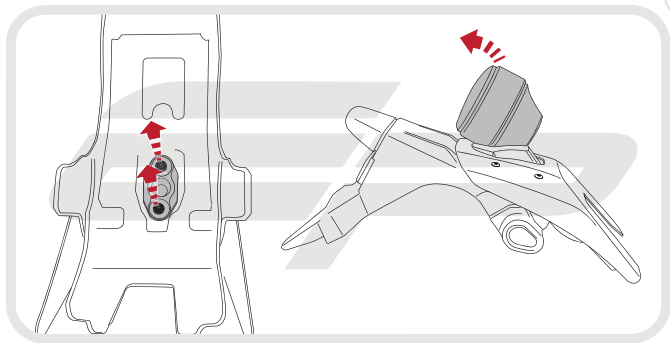



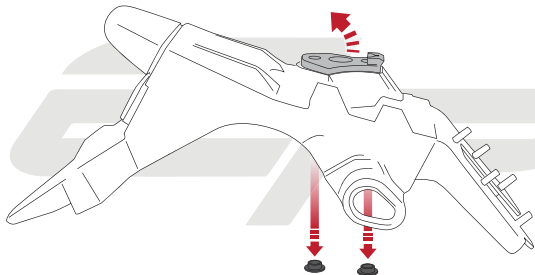

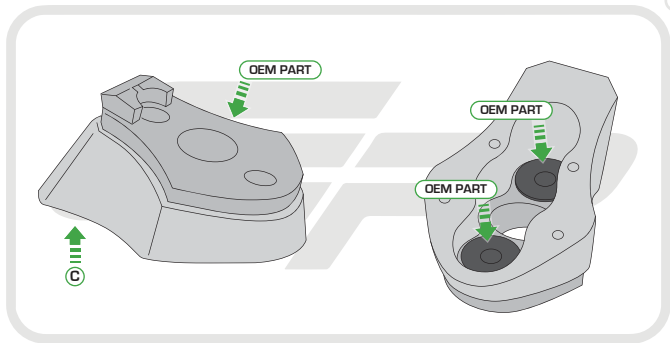

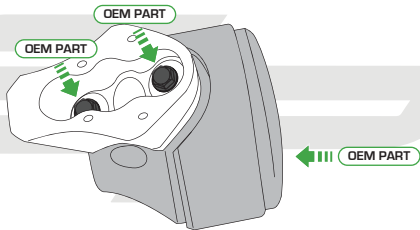

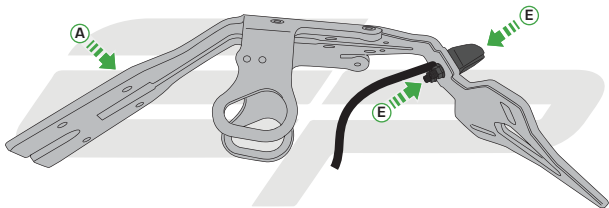

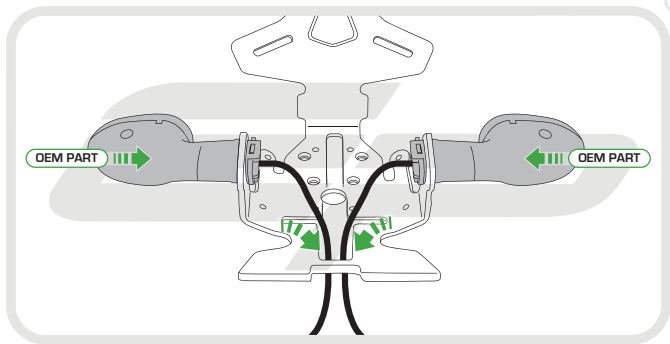

EVOTECH[®]
P E R F O R M A N C E

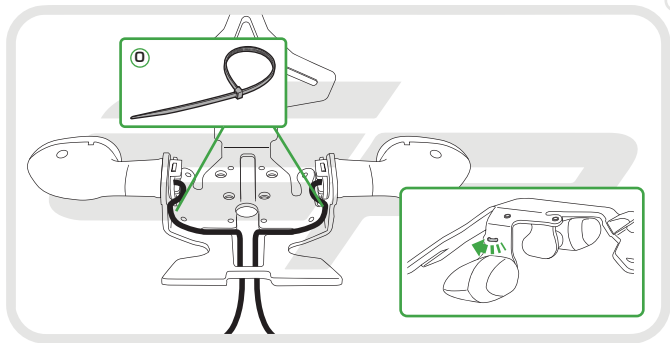

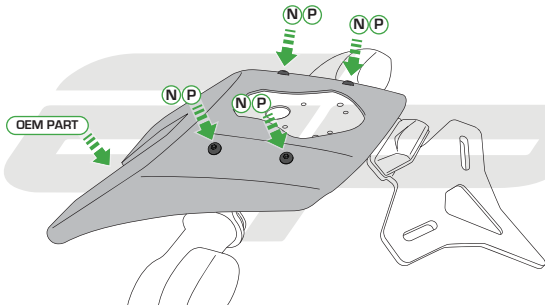

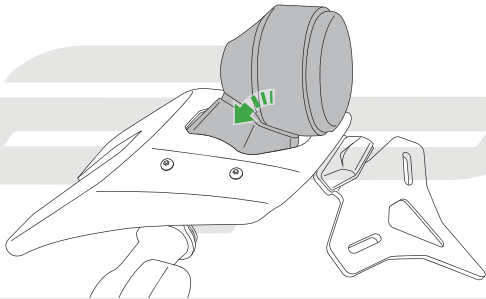

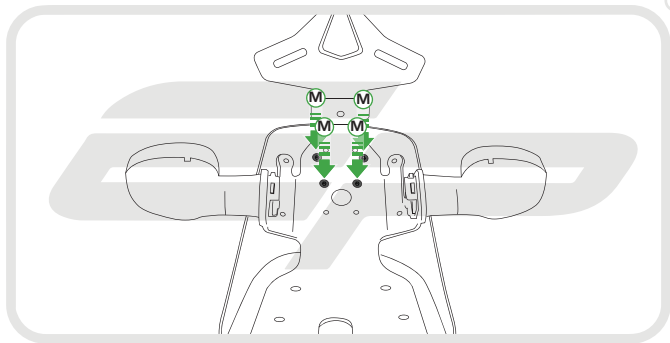

EVOTECH[®]
P E R F O R M A N C E



Caution

Run wires neatly down
the channels

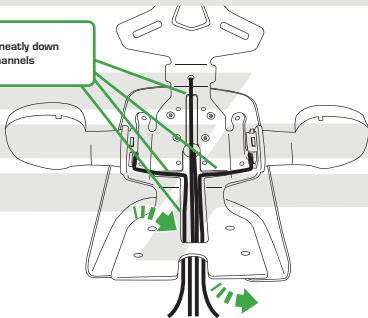



Caution

Run wires neatly down the channel
in both parts ensuring they
do not get trapped or squashed

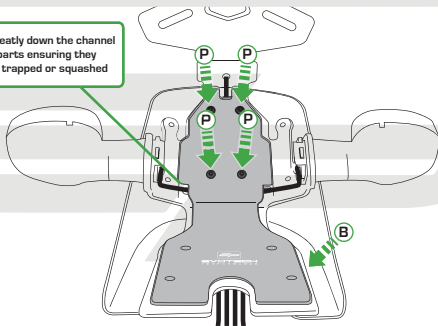

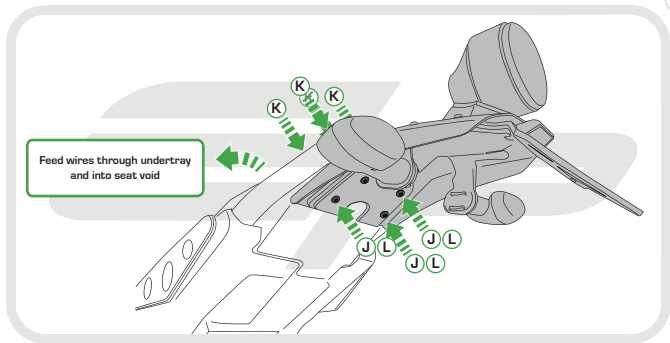

Push Rubber cap over
lock barrel

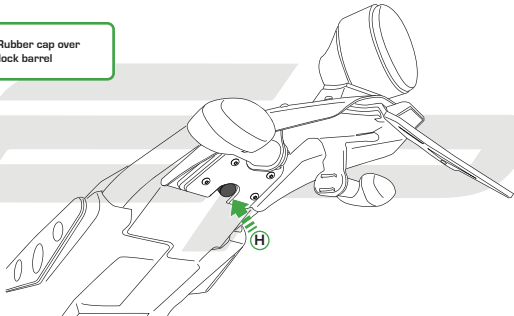

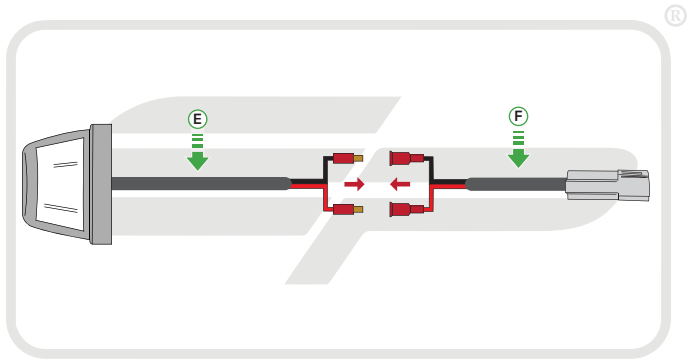

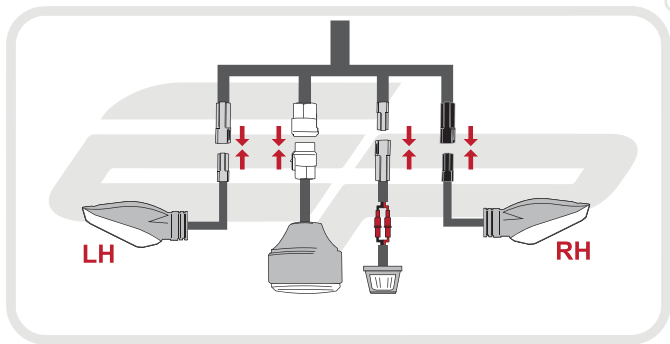



Reverse Stages

2,1

Reflector Bracket Installation

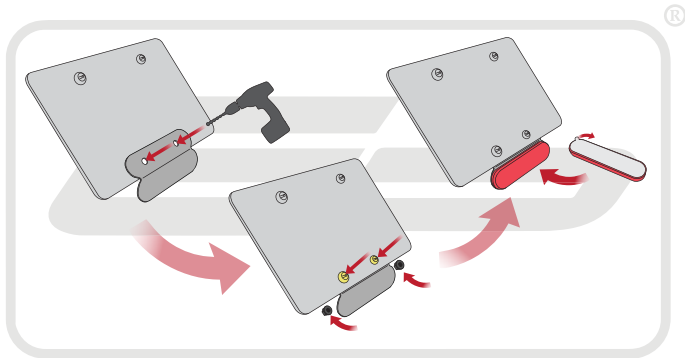

EVOTECH[®]
P E R F O R M A N C E



 **ESSENTIAL CHECKS** 

After installation of your tail tidy ensure that the licence plate does not contact the rear tyre when suspension is fully compressed.

Ensure all electrics including indicators, tail light, brake light and licence plate light lights are working correctly before riding the motorcycle.

It is recommended that periodic inspections are made to ensure that all fixings are fully tightend.



EVOTECH®
P E R F O R M A N C E

www.evotech-performance.com