

VISTA DA "A"  
Flange "25B"

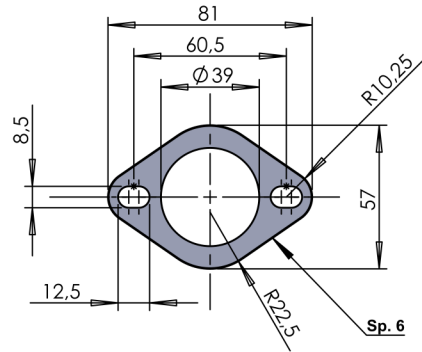

VISTA DA "B"

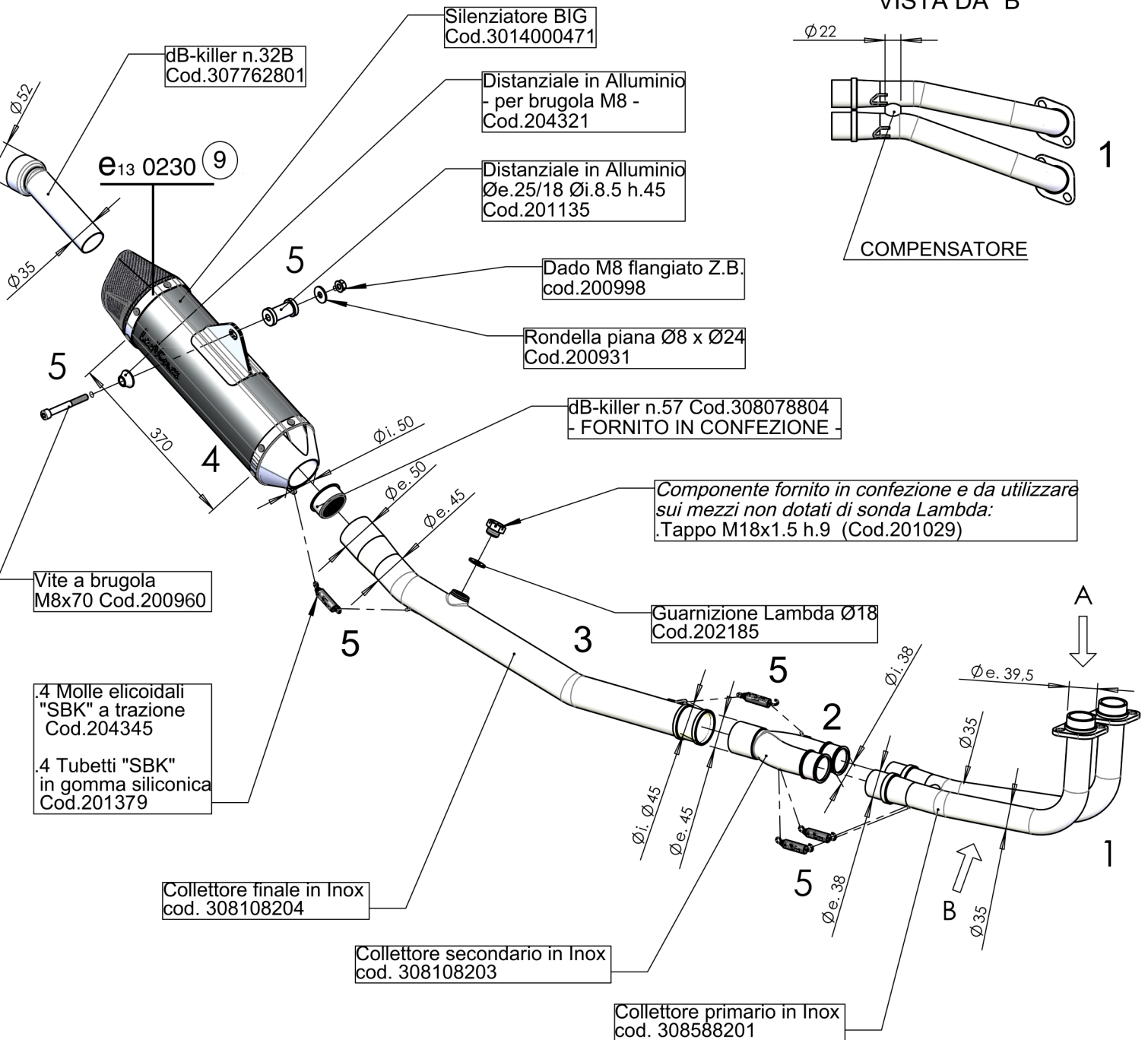
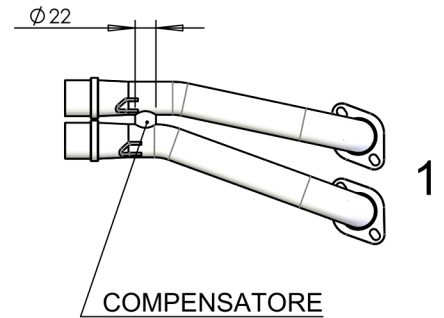

YAMAHA T- MAX 530 i.e. ('12 / '13)

Art. 14000  
 Impianto completo 2/1 LEOVINCE "NERO" <<BIG>>  
 Passaggio STANDARD OMOLOGATO "EVOLUTION II"