



FITTING INSTRUCTIONS FOR LP0336BK
LICENCE PLATE BRACKET



**This kit contains the items pictured and labelled over page.
Some parts may be shown for clarity of instructions only.
Do not proceed until you are sure all parts are present.
Please read all instructions before proceeding.**

**IF IN ANY DOUBT WHEN FITTING OUR PRODUCTS, CONSULT ONE OF OUR DEALERS
OR HAVE FITTED BY A QUALIFIED TECHNICIAN.**

Please note that the way the kit is packed does not necessarily represent the way of mounting to the bike.

In the event of rubber washers being used to hold components onto bolts, these rubber washers can be thrown away.



<u>TOOLS REQUIRED</u>	<u>GENERAL TORQUE SETTINGS</u>
<ul style="list-style-type: none"> • Set of metric Hex keys to include 5mm & 6mm. • Set of metric sockets and wrench. To include 8mm, 10mm & 12mm. <ul style="list-style-type: none"> • Cable cutters 	M4 BOLT = 8Nm M5 BOLT = 12Nm M6 BOLT = 15Nm M8 BOLT = 20Nm M10 BOLT = 40Nm M12 BOLT = 40Nm

LEGEND

ITEM No.	DESCRIPTION	QTY
ITEM 1	MAIN SUPPORT BRACKET	1
ITEM 2	LICENCE PLATE BRACKET	1
ITEM 3	M5 COUNTER SUNK BOLT	4
ITEM 4	M6 BUTTON HEAD BOLT	4
ITEM 5	10mm WASHER	4
ITEM 6	12mm WASHER	8
ITEM 7	M5 NYLOC NUT	4
ITEM 8	M6 NYLOC NUT	4
ITEM 9	NUMBER PLATE LIGHT	1
ITEM 10	CABLE TIES	6
ITEM 11	HEAT SHRINK	3

R&G

Unit 1, Shelley's Lane, East Worldham, Alton, Hampshire, GU34 3AQ

Tel: +44 (0)1420 89007 Fax: +44 (0)1420 87301 www.rg-racing.com Email: info@rg-racing.com



ASSEMBLY DIAGRAM

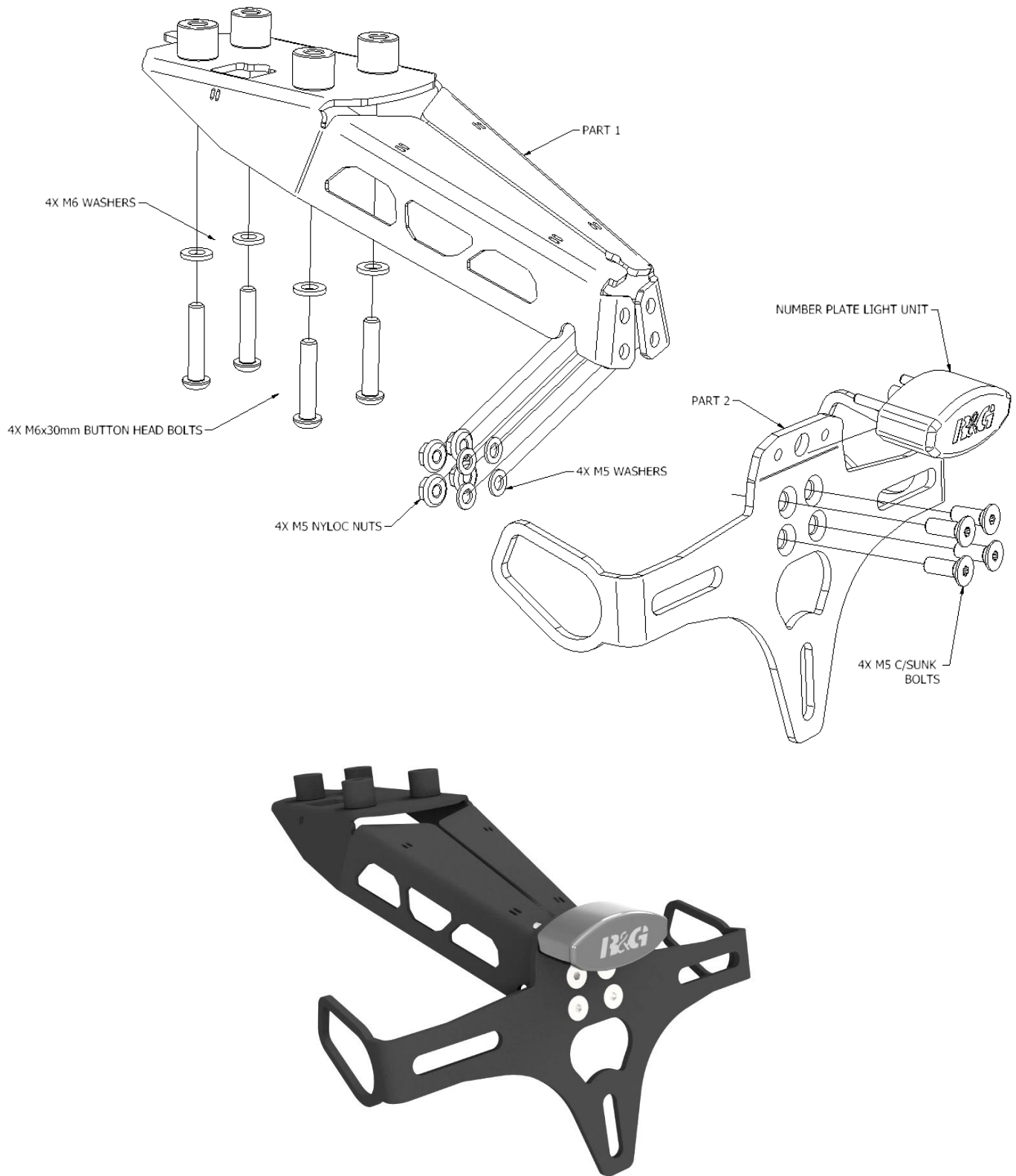

R&G

Unit 1, Shelley's Lane, East Worldham, Alton, Hampshire, GU34 3AQ
Tel: +44 (0)1420 89007 Fax: +44 (0)1420 87301 www.rg-racing.com Email: info@rg-racing.com



FITTING INSTRUCTIONS

Disassembly of OEM Tail Unit:

- Disconnect the wiring connectors going to the OEM Tail Unit which can be found in the position marked in picture 3.
- Remove the OEM tail unit via the four bolts underneath the passenger seat.
- Un-screw all visible bolts on the OEM Tail Unit then remove the OEM indicators for later use.
- Re-assemble the OEM Tail unit without the indicators and store away safely.

Tail Tidy Assembly:

- Attach the OEM indicators and supplied number plate light with connector to the R&G licence plate bracket (**Item 2**)
- Attach the support bracket (**Item 1**) to the licence plate bracket using the supplied countersunk bolts (**Item 3**), washers (**Item 5**) and Nyloc nuts (**Item 6**). As shown in the **Picture 1**.
- Use the supplied heat shrink to cover the number plate light wiring and indicator wiring.
- Pass the number plate light wiring through the central cut out in the support bracket between the two plates, the indicator wiring should be fixed in place using the supplied cable ties via the small cable tie slots cut into the main mounting bracket. The indicator cables should be positioned through the slots on the underside of the main bracket.
- Once fixed in place with cable ties, pass the wiring/connectors through the hole in the top plate of the main bracket.
- Offer up the tail tidy to the motorcycle and pass the connectors through the hole in the undertray.
- Then pass the supplied button head bolts (**Item 4**) with washers (**Item 5**) through the main bracket then through the motorcycles undertray. (**Picture 3**)
- Apply the remaining washers and M6 nyloc nuts to the exposed thread on the inside of the tail unit.
- Connect the indicator and number plate light connectors to the original loom.
- Test the indicators and number plate light function correctly before tightening the bolts fully.
- Then fully tighten the bolts to the required torque spec.

IMPORTANT: FOR SAFETY, ENSURE THE LICENCE PLATE IS PLACED AS HIGH AS POSSIBLE ON THE TAIL TIDY (IT MAY REQUIRE DRILLING). IF FITTING A LICENCE PLATE OF 200MM OR LONGER (INCLUDING ANY SHROUD OR REFLECTOR ATTACHMENT) TO THE BRACKET, BEFORE RIDING, FULLY COMPRESS THE SUSPENSION TO ENSURE NO PART OF THE ASSEMBLY CAN CONTACT THE TYRE WHILE THE VEHICLE IS IN MOTION OR UNDER LOAD. IT IS YOUR RESPONSIBILITY TO CHECK FOR THIS POSSIBILITY AND TAKE AVOIDING ACTION. FAILURE TO CHECK THIS COULD RESULT IN SERIOUS INJURY OR DAMAGE TO THE MOTORCYCLE.

ISSUE 1 14/02/2024 TB

CONSUMER NOTICE

The catalogue description and any exhibition of samples are only broad indications of the Products and R&G may make design changes which do not diminish their performance or visual appeal and supplying them in such state shall conform to the order. The Buyer acknowledges no representation or warranty (other than as to title) has been given or will apply to the Products other than those in R&G's order or confirmation and the Buyer confirms it has chosen the Products as being of merchantable quality and suitable for its particular purposes. Where R&G fits the Products or undertakes other services it shall exercise reasonable skill and care and rectify any fault free of charge unless the workmanship has been disturbed. The Buyer is responsible for ensuring that the warranty on the motorcycle is not affected by the fitting of the Products. On return of any defective Products R&G shall at its option either supply a replacement or refund the purchase money but shall not be liable if the Products have been modified or used or maintained otherwise than in accordance with R&G's or manufacturer's instructions and good engineering practice or if the defect arises from accident or neglect. Other than identified above and subject to R&G not limiting its liability for causing death and personal injury, it shall not be liable for indirect or consequential loss and otherwise its liability shall be limited to the amounts paid by the Buyer for the Products or the fitting or service concerned. These terms do not affect the Buyer's statutory rights.

R&G

Unit 1, Shelley's Lane, East Worldham, Alton, Hampshire, GU34 3AQ

Tel: +44 (0)1420 89007 Fax: +44 (0)1420 87301 www.rg-racing.com Email: info@rg-racing.com

**R&G RACING RETURNS POLICY (NON-FAULTY GOODS)**

Returns must be pre-authorized (if not pre-authorized the return will be rejected). Goods may only be returned direct to us if they were purchased direct from us (customer must prove if necessary). Otherwise to be returned to original vendor. Goods must be in re-sellable condition, in the opinion of R&G Racing. All returns are subject to a 25% restocking and handling fee (25% of the gross value exc. P&P – at the prevailing price at time of purchase). The customer must pay any and all carriage charges. No returns of discontinued products, unless within 14 days of purchase. This policy does not affect your statutory rights and does not refer to faulty goods.

R&G

Unit 1, Shelley's Lane, East Worldham, Alton, Hampshire, GU34 3AQ

Tel: +44 (0)1420 89007 Fax: +44 (0)1420 87301 www.rg-racing.com Email: info@rg-racing.com