

SUZUKI V-STROM 650 '17- / V-STROM 650 XT '17-

M O U N T I N G I N S T R U C T I O N S

REF 21576

OIL CARTER GUARD

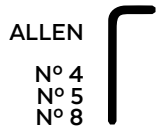

ID	PIEZA/PART	DESCRIPCIÓN	DESCRIPTION	QTY	REF
1		Protector de aluminio	Aluminum protection plate	1	SOPOR5P3PN21576
2		Soporte delantero derecho	Right front support	1	SOPOR5P3DD21576
3		Soporte delantero izquierdo	Left front support	1	SOPOR5P3DI21576
4		Soporte trasero derecho	Right rear support	1	SOPOR5P3TD21576
5		Soporte trasero izquierdo	Left rear support	1	SOPOR5P3TI21576
6		Amortiguador antivibratorio silentblock Ø20x10 (M6x18, int M6x6)	Anti vibration damper silentblock Ø20x10 (M6x18, int M6x6)	4	SILENTBLOCK-523
7		Tornillo M6 x8 DIN7991	M6 x8 DIN7991 screw	4	TORNI-D7991-918
8		Tornillo M6 x16 DIN7991	M6 x16 DIN7991 screw	2	TORNI-D7991-544
9		Tornillo M10x120 DIN 912	M10x120 DIN 912 screw	1	TORNI-D912--919
10		Arandela M10 DIN125	M10 DIN125 washer	1	ARAND-PIM10-574
11		Tuerca M10 DIN985	M10 DIN985 nut	1	TUEA-D985.8-M10
12		Arandela M8 DIN9021	M8 DIN9021 washer	1	ARAND-D9021-625

SUZUKI V-STROM 650 '17- / V-STROM 650 XT '17-

INSTRUCCIONES DE MONTAJE - MOUNTING INSTRUCTIONS - MONTAGEANLEITUNG

1

DISASSEMBLY
DESMONTAJE

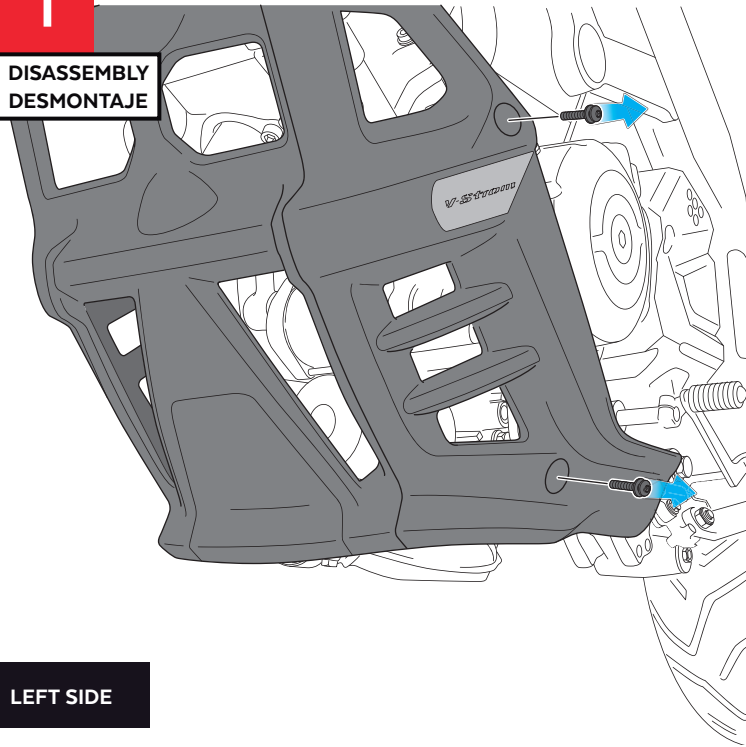

2

DISASSEMBLY
DESMONTAJE

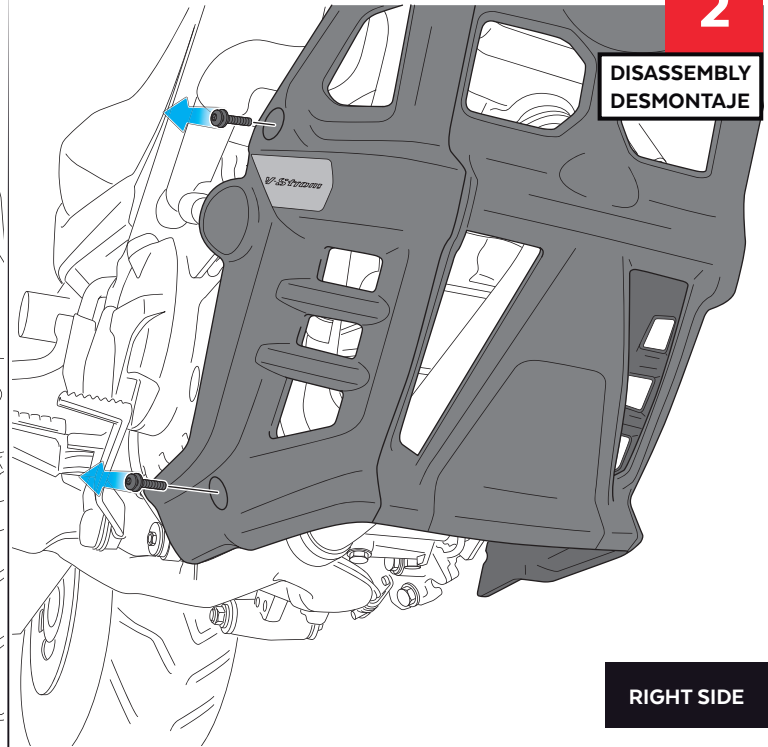

3

DISASSEMBLY
DESMONTAJE

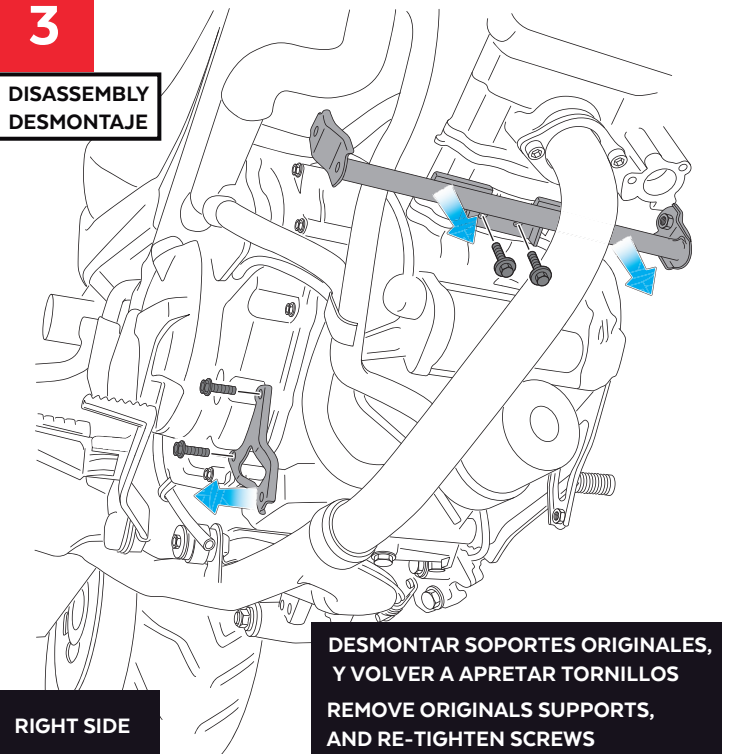

4

DISASSEMBLY
DESMONTAJE

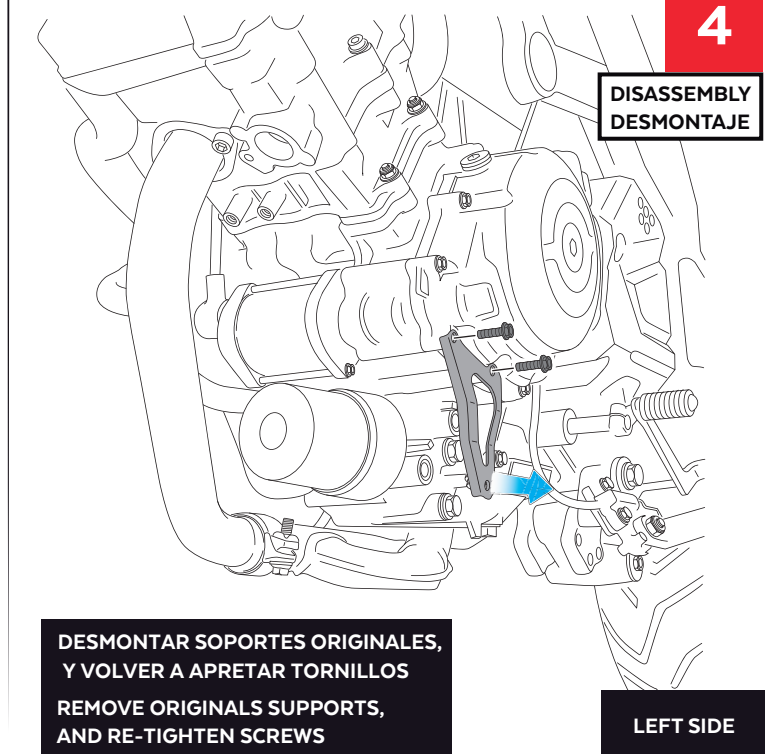

SUZUKI V-STROM 650 '17- / V-STROM 650 XT '17-

INSTRUCCIONES DE MONTAJE - MOUNTING INSTRUCTIONS - MONTAGEANLEITUNG

5

DISASSEMBLY
DESMONTAJE

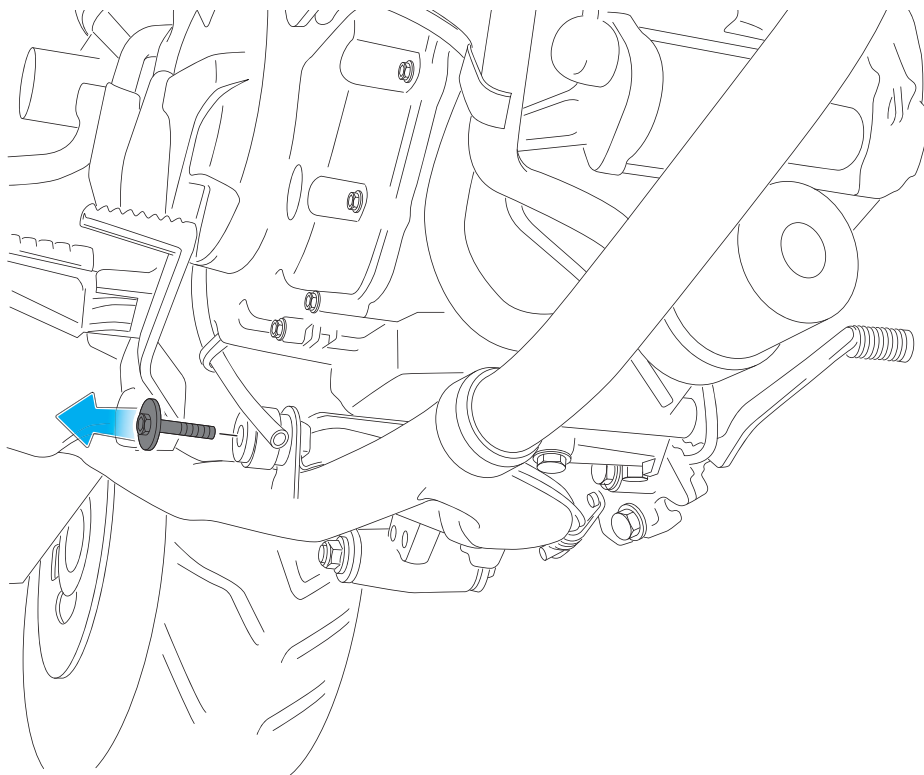

RIGHT SIDE

6

ASSEMBLY
MONTAJE

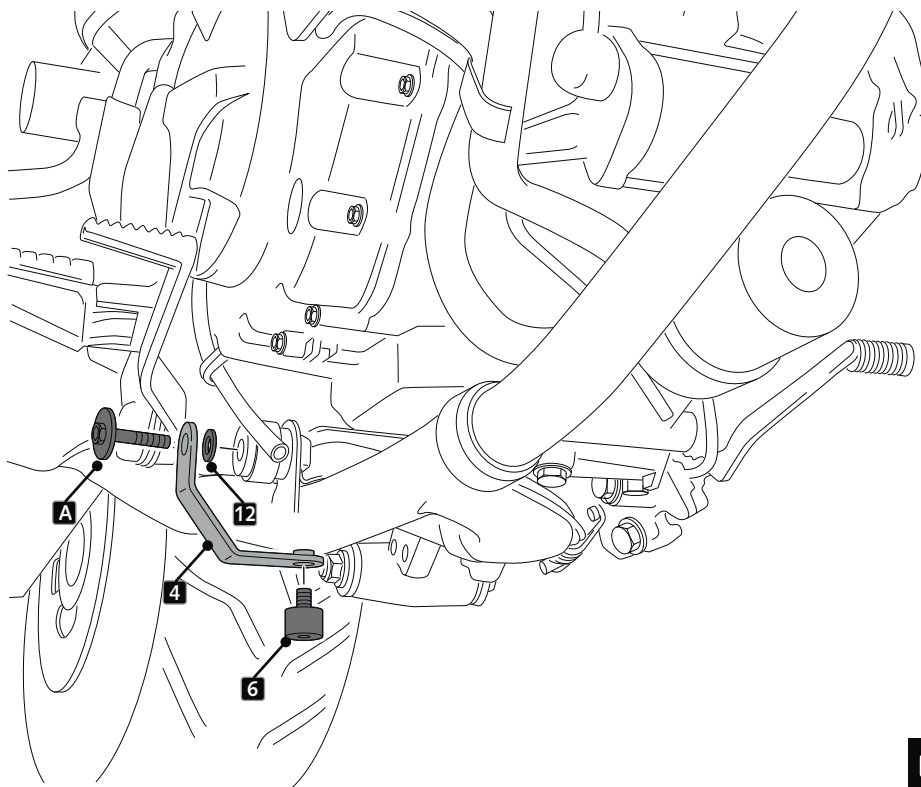

A PIEZA ORIGINAL
ORIGINAL PART

RIGHT SIDE

A Par Apriete - 15 Nm
Tightening Torque - 15 Nm

SUZUKI V-STROM 650 '17- / V-STROM 650 XT '17-

INSTRUCCIONES DE MONTAJE - MOUNTING INSTRUCTIONS - MONTAGEANLEITUNG

7

DISASSEMBLY
DESMONTAJE

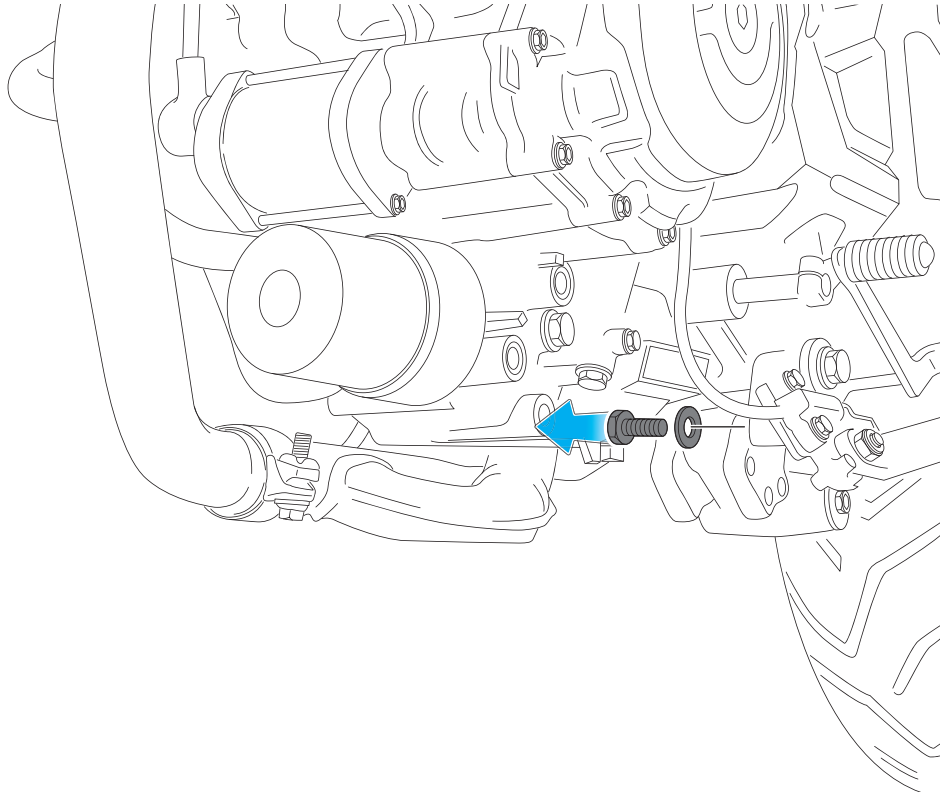

LEFT SIDE

8

ASSEMBLY
MONTAJE

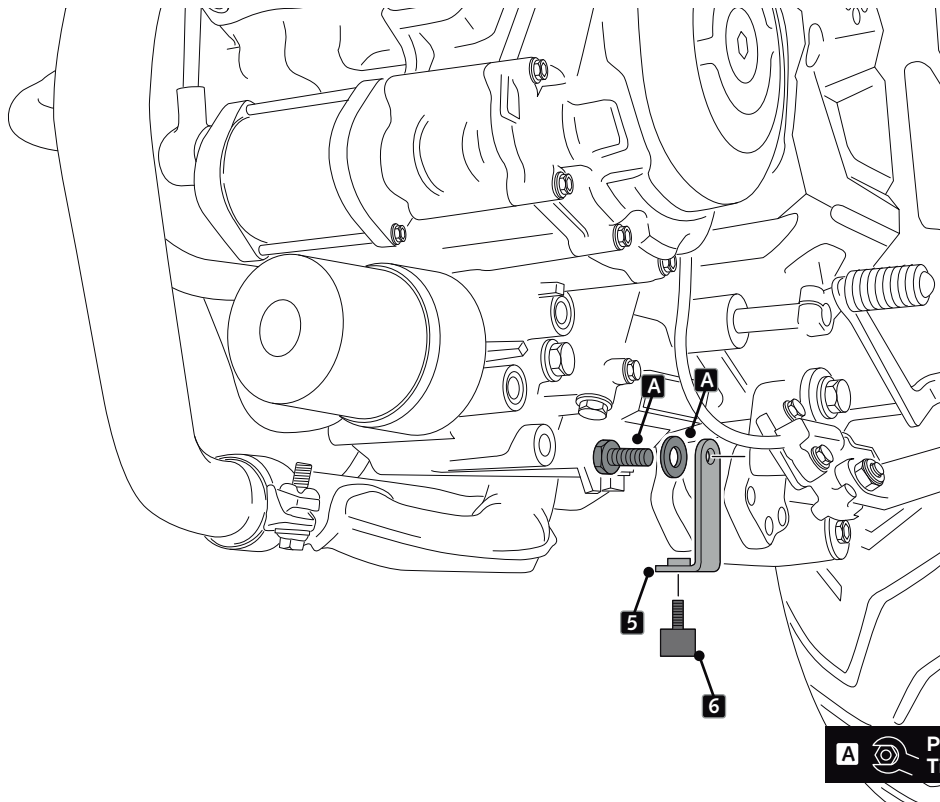

A PIEZA ORIGINAL
ORIGINAL PART

LEFT SIDE

A  Par Apriete - 20 Nm
Tightening Torque - 20 Nm

SUZUKI V-STROM 650 '17- / V-STROM 650 XT '17-

INSTRUCCIONES DE MONTAJE - MOUNTING INSTRUCTIONS - MONTAGEANLEITUNG

9

ASSEMBLY
MONTAJE

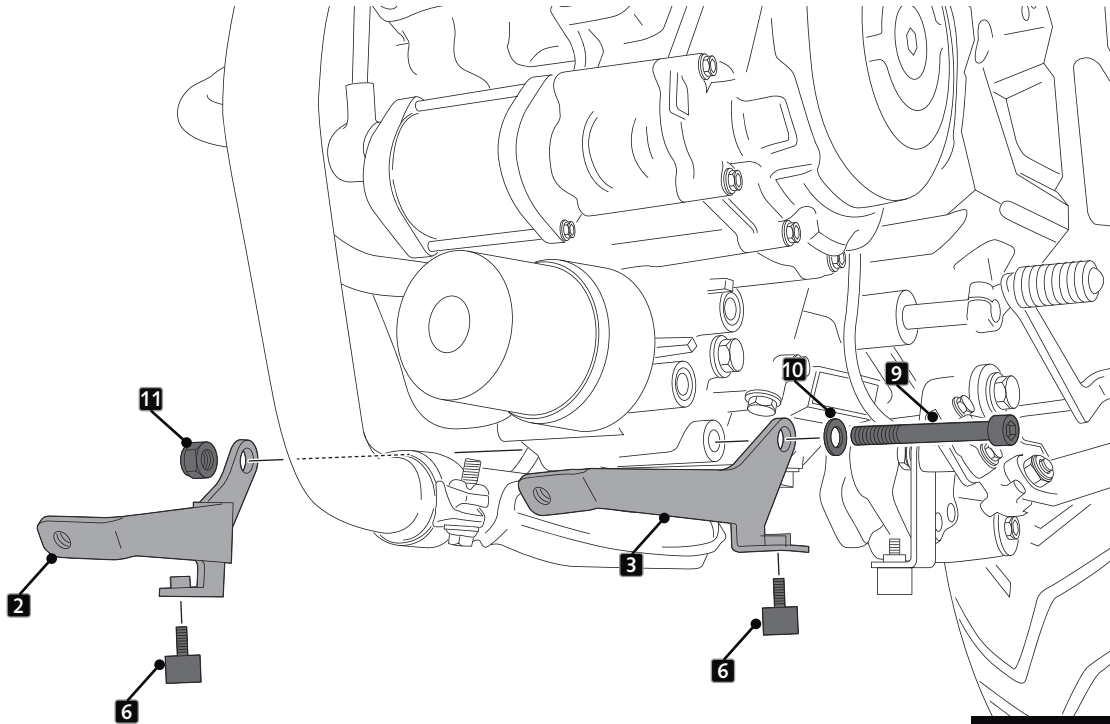

LEFT SIDE

9  Par Apriete - 25 Nm
Tightening Torque - 25 Nm

10

ASSEMBLY
MONTAJE

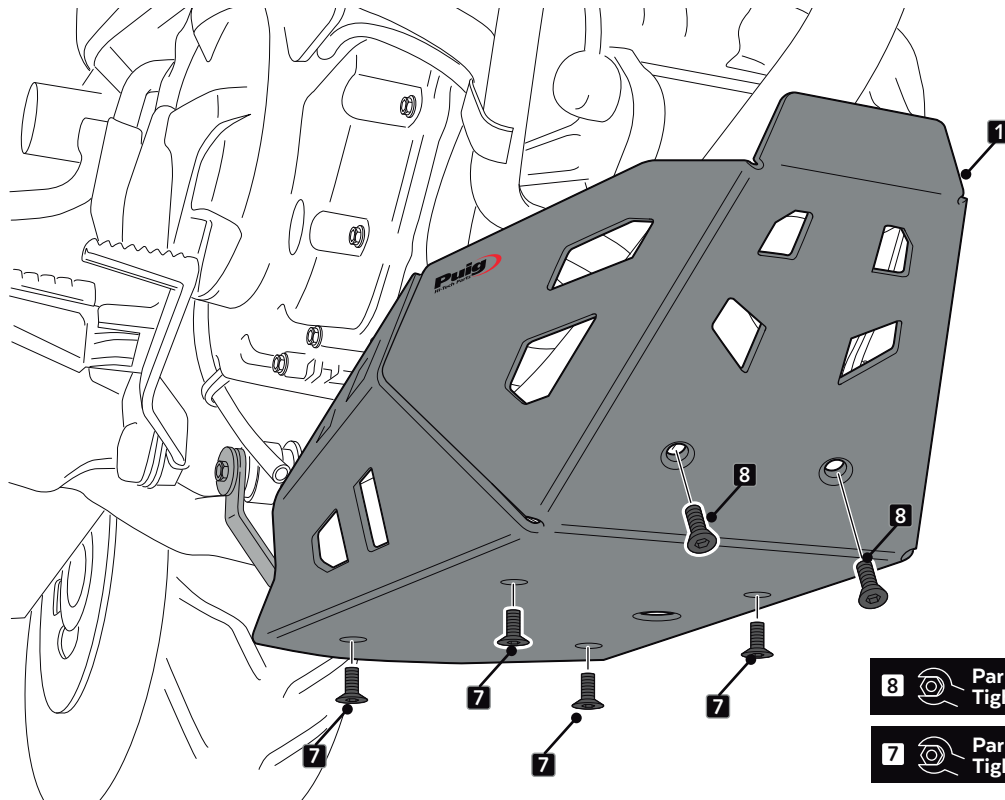

RIGHT SIDE

8  Par Apriete - 10 Nm
Tightening Torque - 10 Nm

7  Par Apriete - 8 Nm
Tightening Torque - 8 Nm